

Parts List			
ITEM	QTY	PART NUMBER	DESCRIPTION
1	1	V20254	2" VALVE BODY
2	1	V20151M	VALVE STEM W/ BEARING
3	1	V20159	2" STEM BUSHING
4	1	V20153	HANDLE
5	1	V20020	2" handle Bolt
6	1	V20021	Handle Washer
7	1	V20255A	2" Valve Ball
8	2	V20264	#151 O'RING, FKM
9	1	V20163	#116 O'RING, FKM
10	2	V20256	2" NPT END PLATE
11	2	V20258A	3" FP Ball Seat
12	4	V20017	3/8-16 X 4" HHCS
13	4	V20018	3/8" LOCKWASHER
14	4	V20019	3/8" HEX NUT

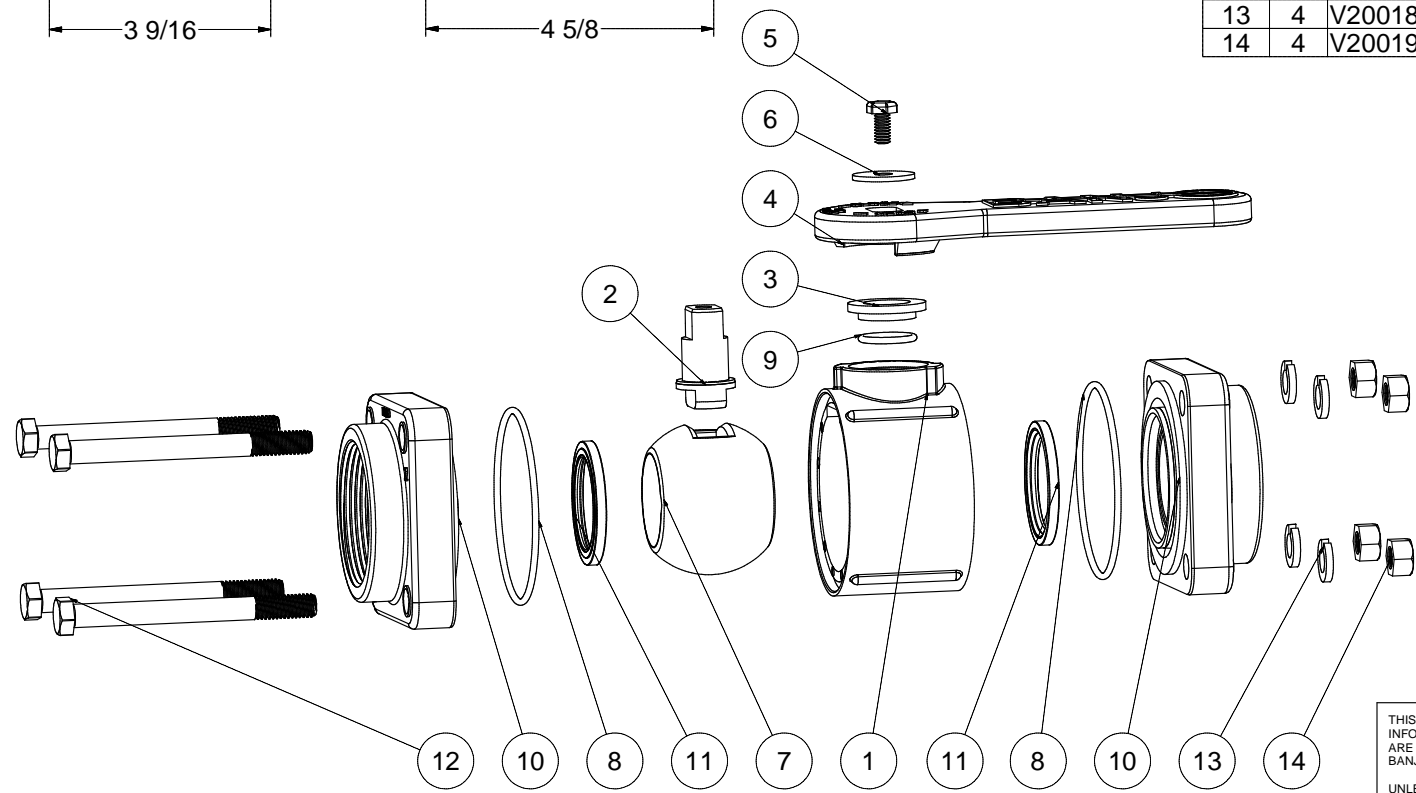

THIS DRAWING AND ALL INFORMATION CONTAINED THEREON ARE THE EXCLUSIVE PROPERTY OF BANJO CORPORATION.
UNLESS SPECIFICALLY NOTED, THIS DRAWING AND ITEMS SHOWN ON THIS DRAWING ARE SUBJECT TO CHANGE AT ANY TIME.

BANJO CORPORATION
150 BANJO DRIVE, CRAWFORDSVILLE, IN 47933
WEB SITE: WWW.BANJOCORP.COM
E-MAIL: SALES1@BANJOCORP.COM

DESCRIPTION
2" Standard ball Valve

PART NUMBER
V200